

# C-SUD-110M2T1 \* - \* \* \*

Series  
 Type  
 Color  
 B : Black  
 Material  
 L : LCP

Shell  
 N : Nickel Plated

Version  
 0 : 3u"  
 1 : 5u"  
 2 : 15£g"  
 3 : 30£g"

| REV | ZONE | REVISION | DATE | APPD. |
|-----|------|----------|------|-------|
|     |      |          |      |       |
|     |      |          |      |       |
|     |      |          |      |       |

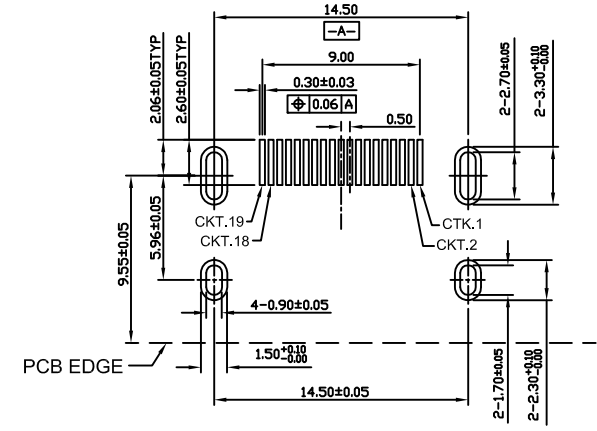
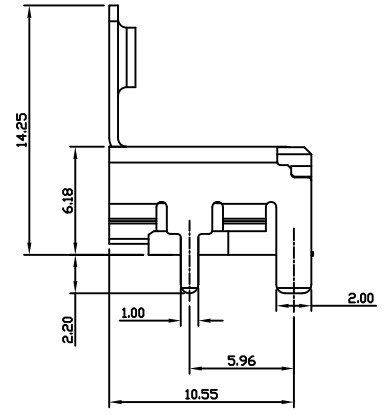
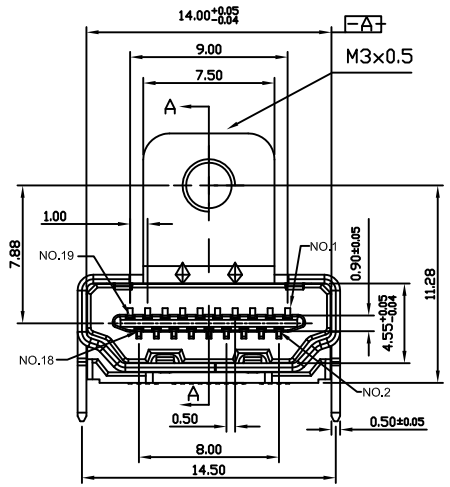

RECOMMENDED PCB LAYOUT  
TOP VIEW

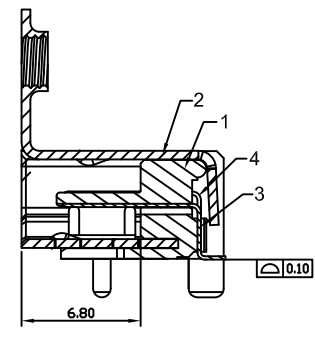
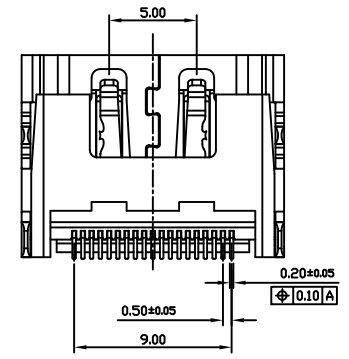

SECTION A-A

| NO. | NAME      | MATERIAL     | PLATING     |
|-----|-----------|--------------|-------------|
| 1   | HOUSING   | LCP          |             |
| 2   | SHELL     | Alloy        | Ni-Plated   |
| 3   | CONTACT 1 | Copper Alloy | Gold-Plated |
| 4   | CONTACT 2 | Copper Alloy | Gold-Plated |



POWERWAY ELECTRONICS CO.,LTD.  
 博 歲 電 子 股 份 有 限 公 司

| COMPUTER NO.       |       |      | UNIT       | SCALE  | PART NAME                                |      |  |
|--------------------|-------|------|------------|--|--|------|--|
| D:\DWG\SUD-110M2T1 |       |      | mm         | 1:1  | HDMI A Type 19P/F<br>90° SMT With Flange |      |  |
| APPD.              | CKD.  | DWG. | DATE       | TOLERANCE  | PART NO.                                 | REV. |  |
|                    | Aaron | Eric | 2010-12-08 | 0.000mm ± 0.075mm<br>0.00 mm ± 0.20 mm<br>0.0 mm ± 0.25 mm |  | A    |  |