

NO.	NAME	MATERIAL	FINISH
1	HOUSING	Nylon / Lcp	
2	PIN TEAM	PHOS. BRONZE	Gold-Tin Plated
3	SHELL	BRASS	Ni Plated

REV	ZONE	REVISION	DATE	APPD.

### SUA-110E9 \* - \* \* \*

Series \_\_\_\_\_  
 Type \_\_\_\_\_  
 B : Black \_\_\_\_\_  
 Material \_\_\_\_\_  
 P : Nylon \_\_\_\_\_  
 L : Lcp \_\_\_\_\_

Shell  
 N : Nickel Plated \_\_\_\_\_

Version  
 1 : 1.1 \_\_\_\_\_  
 2 : 2.0 \_\_\_\_\_

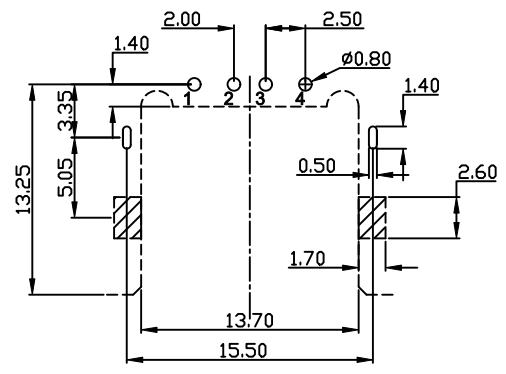
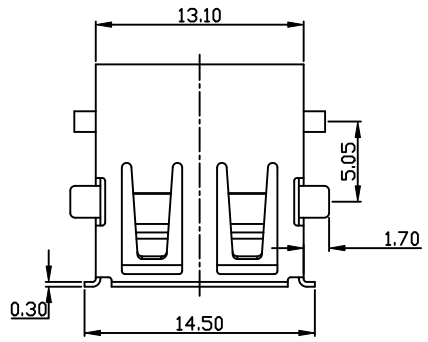

**RECOMMEND PCB LAYOUT  
TOP VIEW**

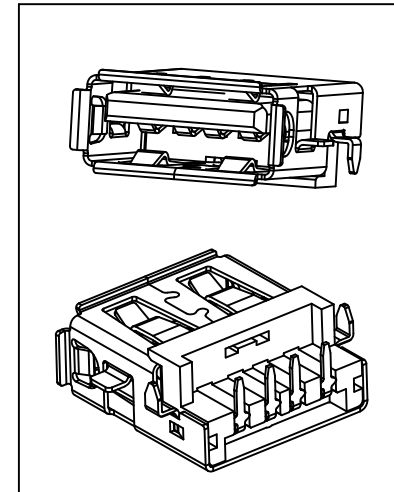
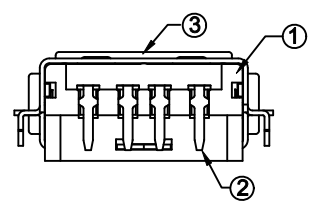
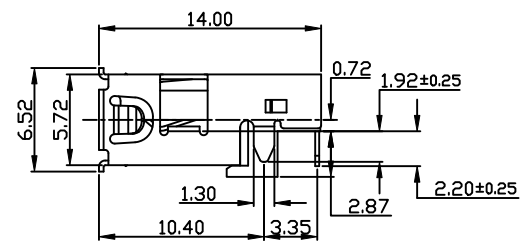
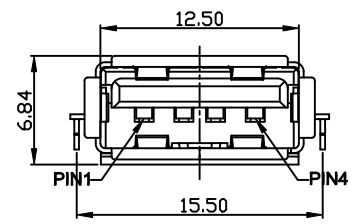

**POWERWAY ELECTRONICS CO.,LTD.**  
**博歲電子股份有限公司**

COMPUTER NO.			UNIT	SCALE	PART NAME	
D:\DWG\SUA-110E9			mm	1:1	USB. TYPE A FLAT 90° DIP	
APPD.	CKD.	DWG.	DATE	TOLERANCE		REV.
	Michael	Chindge	2009-06-17	0.000mm ± 0.15mm 0.00 mm ± 0.25 mm 0.0 mm ± 0.35 mm		A.0

MODEL	SUA-110E9*-*-*	PAGE 1 OF 1
-------	----------------	-------------

