

NO.	NAME	MATERIAL	FINISH
1	HOUSING	Nylon / Lcp	
2	CONTACT	PHOS. BRONZE	Gold-Tin Plated
3	SHELL	BRASS	Ni Plated

REV	ZONE	REVISION	DATE	APPD.

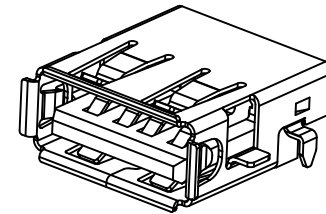

RECOMMENDED PCB LAYOUT
TOP VIEW

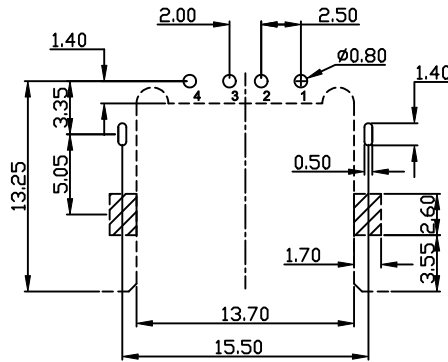
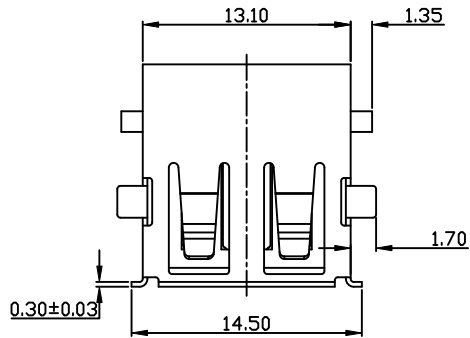
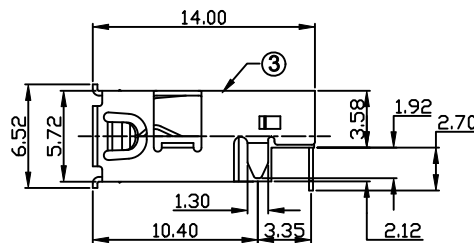
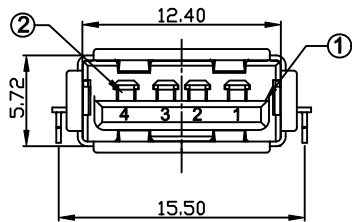

SUA-110E7 *-* ** *

Series
Type
B: Black
Material
P : Nylon
L : Lcp

Shell
N : Nickel Plated

Version
1 : 1.1
2 : 2.0



POWERWAY ELECTRONICS CO.,LTD.
博 歲 電 子 股 份 有 限 公 司

COMPUTER NO.			UNIT	SCALE	PART NAME	
D:\DWG\SUA-110E7			mm	1:1	USB. TYPE A REVERSE FLAT 90° DTP	
APPD.	CKD.	DWG.	DATE	TOLERANCE		REV.
	Michael	Chindge	2009-05-26	0.000mm ± 0.15mm 0.00 mm ± 0.25 mm 0.0 mm ± 0.35 mm		A.0

MODEL SUA-110E7*-* ** * PAGE 1 OF 1

